

USER MANUAL

LX G-meter

Standalone digital G-meter with built in flight recorder

Version 1.0



1	Important Notices	3
1.1	Limited Warranty	3
2	Packing Lists	4
3	Installation	5
3.1	Cut-Outs	5
3.1.1	Cut-Out for LXNAV G-meter	5
4	LXNAV G-meter Basics	6
4.1	The LXNAV G-meter at a Glance	6
4.1.1	LXNAV G-meter Features	6
4.1.2	Interfaces	6
4.1.3	Technical Data	6
5	System Description	7
5.1	Push Button	7
5.2	Switching on the Unit	7
5.3	User Input	7
5.3.1	Text Edit Control	8
5.3.2	Selection Control	9
5.3.3	Checkbox and Checkbox List	9
5.3.4	Slider Selector	9
5.4	Switching Off	9
6	Operating Modes	10
6.1	Main mode	11
6.2	Quick Access Menu	11
6.3	Setup Mode	11
6.3.1	Logbook	11
6.3.2	Indicator	12
6.3.3	Display	12
6.3.3.1	Automatic Brightness	12
6.3.3.2	Minimum Brightness	12
6.3.3.3	Maximum Brightness	13
6.3.3.4	Get Brighter In	13
6.3.3.5	Get Darker In	13
6.3.3.6	Brightness	13
6.3.3.7	Night Mode Darkness	13
6.3.4	Hardware	13
6.3.4.1	Limits	13
6.3.4.2	System Time	13
6.3.4.3	Airspeed Offset	14
6.3.5	Password	14
6.3.6	About	14
7	Wiring and static ports	15
7.1	Pinout	15
7.2	Static ports connection	16
8	Revision history	17

1 Important Notices

The LXNAV G-METER system is designed for VFR use only. All information is presented for reference only. It is ultimately the pilot's responsibility to ensure that the aircraft is being flown in accordance with the manufacturer's aircraft flight manual. The g-meter must be installed in accordance with applicable airworthiness standards according to the country of registration of the aircraft.

Information in this document is subject to change without notice. LXNAV reserves the right to change or improve their products and to make changes in the content of this material without obligation to notify any person or organisation of such changes or improvements.



A Yellow triangle is shown for parts of the manual which should be read carefully and are important for operating the LXNAV G-METER system.



Notes with a red triangle describe procedures that are critical and may result in loss of data or any other critical situation.



A bulb icon is shown when a useful hint is provided to the reader.

1.1 Limited Warranty

This LXNAV g-meter product is warranted to be free from defects in materials or workmanship for two years from the date of purchase. Within this period, LXNAV will, at its sole option, repair or replace any components that fail in normal use. Such repairs or replacement will be made at no charge to the customer for parts and labour, the customer shall be responsible for any transportation cost. This warranty does not cover failures due to abuse, misuse, accident, or unauthorised alterations or repairs.

THE WARRANTIES AND REMEDIES CONTAINED HEREIN ARE EXCLUSIVE AND IN LIEU OF ALL OTHER WARRANTIES EXPRESSED OR IMPLIED OR STATUTORY, INCLUDING ANY LIABILITY ARISING UNDER ANY WARRANTY OF MERCHANTABILITY OR FITNESS FOR A PARTICULAR PURPOSE, STATUTORY OR OTHERWISE. THIS WARRANTY GIVES YOU SPECIFIC LEGAL RIGHTS, WHICH MAY VARY FROM STATE TO STATE.

IN NO EVENT SHALL LXNAV BE LIABLE FOR ANY INCIDENTAL, SPECIAL, INDIRECT OR CONSEQUENTIAL DAMAGES, WHETHER RESULTING FROM THE USE, MISUSE, OR INABILITY TO USE THIS PRODUCT OR FROM DEFECTS IN THE PRODUCT. Some states do not allow the exclusion of incidental or consequential damages, so the above limitations may not apply to you. LXNAV retains the exclusive right to repair or replace the unit or software, or to offer a full refund of the purchase price, at its sole discretion. SUCH REMEDY SHALL BE YOUR SOLE AND EXCLUSIVE REMEDY FOR ANY BREACH OF WARRANTY.

To obtain warranty service, contact your local LXNAV dealer or contact LXNAV directly.

2 Packing Lists

- LXNAV g-Meter
- Power supply cable
- Calibration chart by MIL-A-5885 paragraph 4.6.3 (Optional)

3 Installation

The LXNAV G-meter requires a standard 57mm cut-out. Power supply scheme is compatible to any FLARM device with RJ12 connector. Recommended fuse is 1A. On the back it has fitted two pressure ports with dedicated labels that shows their functions.

More about pinout and pressure ports connections is available in chapter 7: *Wiring and static ports*.



Pressure ports are available only in "FR" version

3.1 Cut-Outs

3.1.1 Cut-Out for LXNAV G-meter

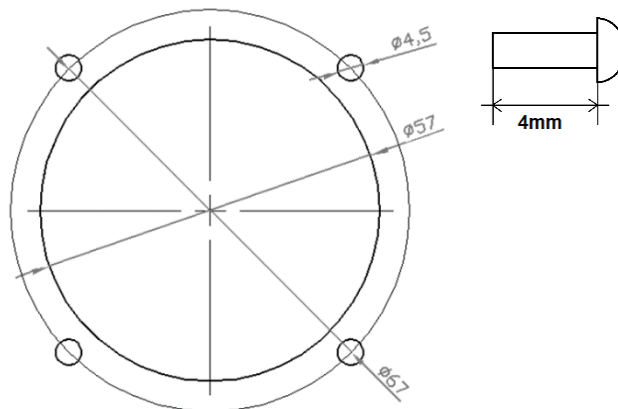

The length of the screw is limited to maximum 4mm!

4 LXNAV G-meter Basics

4.1 The LXNAV G-meter at a Glance

The LXNAV g-meter is standalone unit designed to measure, indicate and log g-forces. The unit has standard dimensions that will fit into the instrument panel with an opening of 57 mm diameter.

The unit has an integrated high precision digital pressure sensor and inertial system. The sensors are sampled more than 100 times per second. Real Time Data is displayed on a QVGA 320x240 pixel 2.5-inch high brightness colour display. To adjust values and settings the LXNAV g-meter has three push buttons.

4.1.1 LXNAV G-meter Features

- An extremely bright 2.5" QVGA colour display readable in all sunlight conditions with the ability to adjust the backlight
- 320x240 pixels colour screen for additional information such as minimum and maximum g-force
- Three push buttons are used for input
- G-force up to +-16G
- Built-in RTC (Real time clock)
- Logbook
- 100 Hz sampling rate for very fast response.

4.1.2 Interfaces

- Serial RS232 input/output
- Micro SD card

4.1.3 Technical Data

- Power input 8-32V DC
- Consumption 90-140mA@12V
- Weight 200g
- Dimensions: 57 mm cut-out 61x61x48mm

5 System Description

5.1 Push Button

LXNAV G-meter has three push buttons. It detects short or long presses of the push button. A short press means just a click; a long press means pushing the button for more than one second.

The three buttons between have fixed functions. The top button is ESC (CANCEL), the middle is to switch between modes and the lower button is the ENTER (OK) button. The upper and lower buttons are also used to rotate between subpages in the WPT and TSK modes.

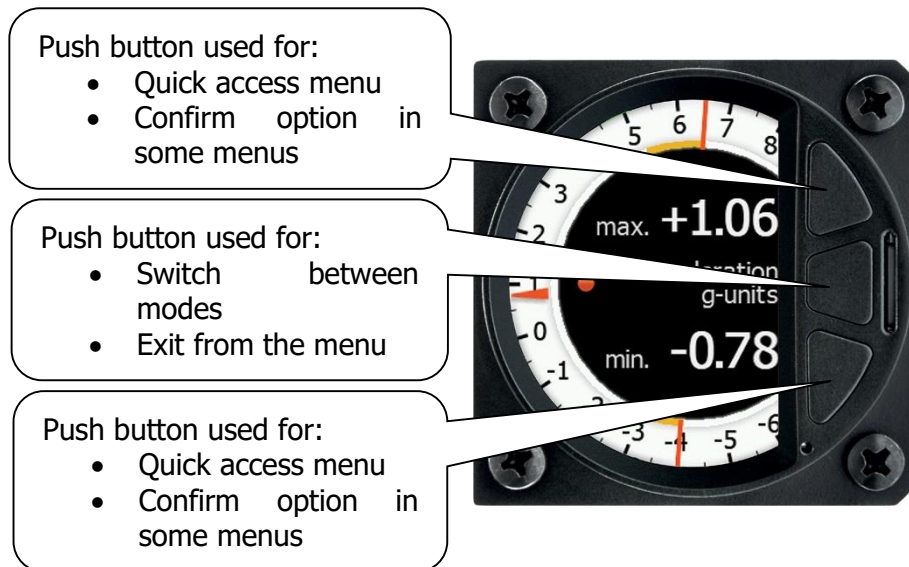

5.2 Switching on the Unit

The unit will power on and will be ready for immediate use.

5.3 User Input

The LXNAV G-meter user interface consists of dialogues which have various input controls. They are designed to make the input of names, parameters, etc., as easy as possible. Input controls can be summarized as:

- Text editor
- Spin controls (Selection control)
- Checkboxes
- Slider control

5.3.1 Text Edit Control

The Text Editor is used to input an alphanumeric string; the picture below shows typical options when editing text/numbers. Use the upper and lower button to change the value at the current cursor position.

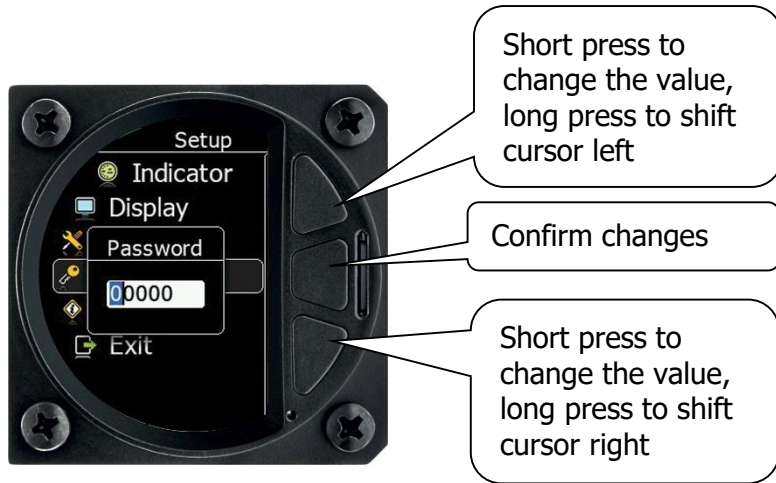

Once the required value is selected, long press the lower push button to move to the next character selection. To move back to the previous character, long press the upper push button. When you have finished editing press the middle push button. A long press of the middle push button exits from the edited field ("control") without any changes.



5.3.2 Selection Control

Selection boxes, also known as combo boxes, are used to select a value from a list of predefined values. Use the top or bottom button scroll through the list. With middle button confirms the selection. Long press to middle button cancel changes.



5.3.3 Checkbox and Checkbox List

A checkbox enables or disables a parameter. Press the middle button to toggle the value. If an option is enabled a check mark will be displayed, otherwise an empty rectangle will be displayed.



5.3.4 Slider Selector

Some values, such as volume and brightness, are displayed as a slider icon.



With a push of the middle button you can activate the slide control and then by rotating the knob you can select the preferred value and confirm it via the push button.

5.4 Switching Off

The unit will switch off when no external power supply is present.

6 Operating Modes

The LXNAV G-meter has two operating modes: Main mode and Setup mode.

Main Mode



Setup Mode

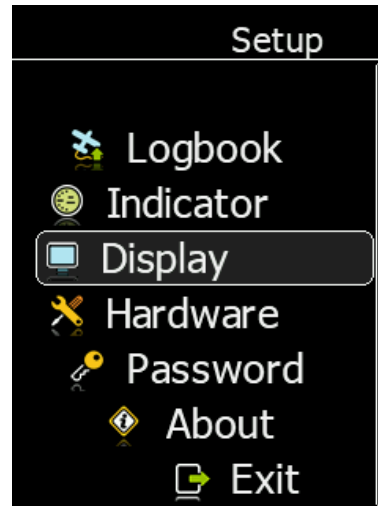

- **Main mode:** Shows g-force scale, with maximums and minimums.
- **Setup mode:** For all aspects of the setup of the LXNAV g-meter.

With up or down menu, we will enter the quick access menu.



6.1 Main mode



6.2 Quick Access Menu

In the quick access menu we can reset the maximum displayed positive and negative g-load or switch to night mode. The user must confirm switching to night mode. If is not confirmed in 5 seconds, it will switch back to normal mode.



6.3 Setup Mode

6.3.1 Logbook

The logbook menu displays the list of flights. If the RTC time is set properly the take-off and landing time shown will be correct. Each flight item consists of the maximum positive g-load, the maximum negative g-load from the flight and the maximum IAS.



This function is available only with "FR" version.

6.3.2 Indicator

The theme and needle type can be adjusted in this menu.



6.3.3 Display



6.3.3.1 Automatic Brightness

If the Automatic Brightness box is checked the brightness will be automatically adjusted between the minimum and maximum parameters set. If the Automatic Brightness is unchecked the brightness is controlled by the brightness setting.

6.3.3.2 Minimum Brightness

Use this slider to adjust the minimum brightness for the Automatic Brightness option.

6.3.3.3 Maximum Brightness

Use this slider to adjust the maximum brightness for the Automatic Brightness option.

6.3.3.4 Get Brighter In

The user can specify in which time period the brightness can reach the required brightness.

6.3.3.5 Get Darker In

The user can specify in which time period the brightness can reach the required brightness.

6.3.3.6 Brightness

With the Automatic Brightness unchecked you can set the brightness manually with this slider.

6.3.3.7 Night Mode Darkness

Set the percentage of the brightness to be used after a press on the NIGHT mode button.

6.3.4 Hardware

Hardware menu consist of three items:

- Limits
- System time
- Airspeed offset



6.3.4.1 Limits

In this menu user can set the limits of indicator

- **Min red zone limit** is red marker for maximum negative g-load
- **Max red zone limit** is red marker for maximum positive g-load
- **Warning zone min** is yellow area of caution for negative g-load
- **Warning zone max** is yellow area of caution for positive g-load



G-force sensor works up to +-16g.

6.3.4.2 System Time

In this menu the user can set the local time and date. Available is also an offset from UTC. UTC is used within the flight recorder. All flights are logged in UTC.

6.3.4.3 Airspeed Offset

In case of any drift of the airspeed pressure sensor, the user can adjust the offset, or align it to zero.



Do not do autozero, when airborne!

6.3.5 Password



01043 - Auto zero of the pressure sensor

32233 - Format device (all data will be lost)

00666 - Reset all settings to factory default

16250 - Show debug info

99999 - Delete complete logbook

Logbook deletion is PIN protected. Each owner of the unit has their own unique PIN code. Only with this pin code is it possible to delete the logbook.

6.3.6 About

The About screen displays the serial number of the unit and firmware version.



7 Wiring and static ports

7.1 Pinout

Power connector is pin compatible with S3 power or any other FLARM cable with RJ12 connector.

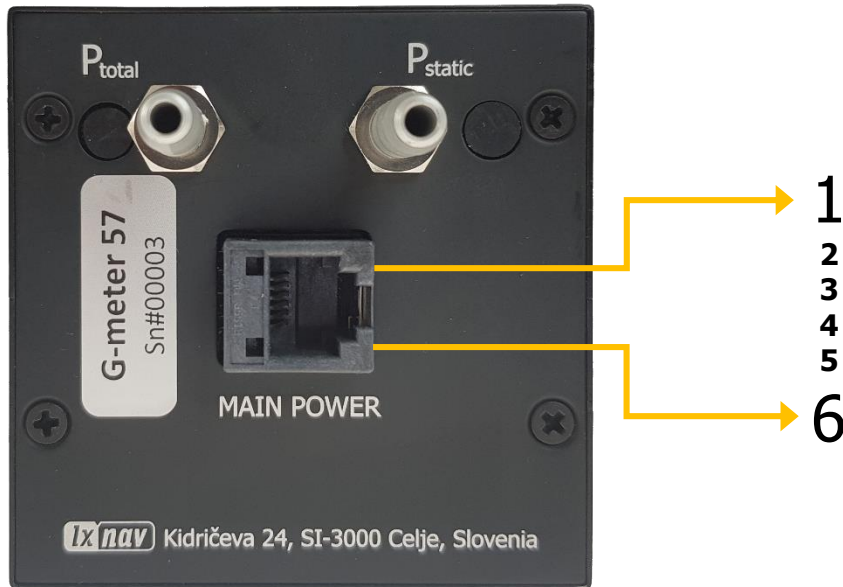

Pin Number	Description
1	Power supply input
2	No connection
3	Ground
4	RS232 RX (data in)
5	RS232 TX (data out)
6	Ground

7.2 Static ports connection

Two ports are on the back of G-meter unit:

- P_{static} static pressure port
- P_{total} pitot or total pressure port

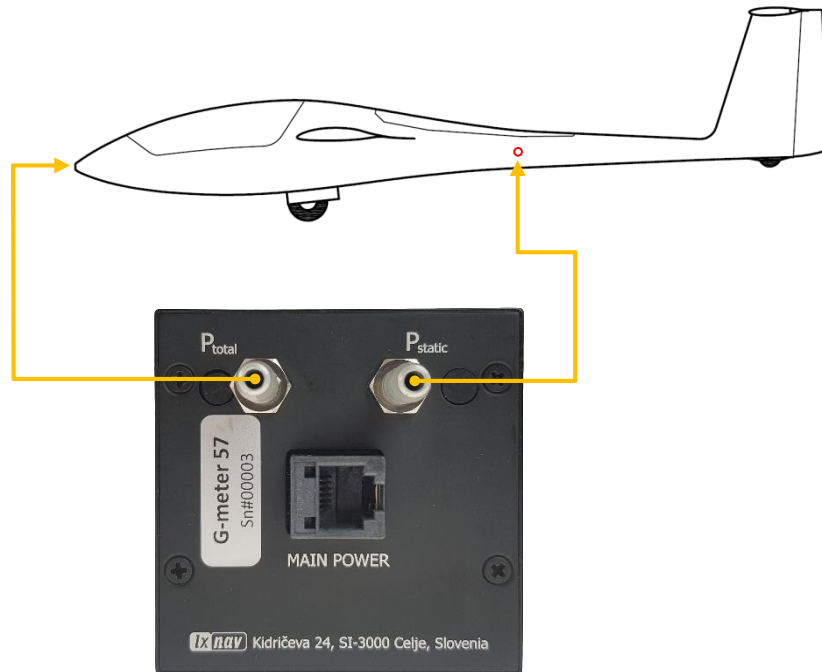

8 Revision history

Rev	Date	Comments
1	April 2020	Initial release
2	April 2020	Review of English language content
3	May 2020	Updated chapter 7
4	May 2020	Updated chapter 6.3.4.1
5	September 2020	Updated chapter 6
6	September 2020	Updated chapter 3
7	September 2020	Style update
8	September 2020	Corrected chapter 5.3, updated chapter 2

The pilot's choice



LXNAV d.o.o.

Kidričeva 24, SI-3000 Celje, Slovenia

T: +386 592 334 00 | F:+386 599 335 22 | info@lxnav.com

www.lxnav.com