

Flap Selector and single flap controller

User manual

Revision 5



LXNAV d.o.o. • Kidričeva 24, 3000 Celje, Slovenia • tel +386 592 33 400 fax +386 599 33 522
info@lxnav.com • www.lxnav.com

1	Important Notices	3
1.1	Limited Warranty	3
2	Revision History	4
3	Packing Lists	6
4	Technical Data	7
4.1	Power and Consumption	7
4.2	Size and Weight	7
5	System description	8
5.1	Part numbers	8
5.2	Flap selector	8
5.2.1	Flap selection switch	8
5.2.2	Buttons at the back side of the unit	8
5.2.3	Switching on the Unit	8
5.2.4	Switching Off	8
5.3	Flap controller box	9
6	Operating Modes	10
6.1	Normal mode	10
6.1.1	Error states	10
6.2	Setup mode (Standalone version)	10
7	Firmware Update	12
8	Backup - manual/automatic - switch flip over (optional)	13
9	Wirings	14
9.1	FLAP controller standalone version	14
9.2	Flap/RPM controller pinout and wiring diagram	15
9.3	Flap motor control backup switch	16
10	Dimensions	17
10.1	Flap Selector	17
10.2	Backup switch	18
10.3	Standalone box	19

1 Important Notices

Information in this document is subject to change without notice. LXNAV reserves the right to change or improve their products and to make changes in the content of this material without obligation to notify any person or organization of such changes or improvements.



A Yellow triangle is shown for parts of the manual which should be read very carefully and are important for operating the Flap Selector.



Notes with a red triangle describe procedures which are critical and may result in loss of data or any other critical situation.



A bulb icon is shown when a useful hint is provided to the reader.

1.1 Limited Warranty

This Flap Selector product is warranted to be free from defects in materials or workmanship for two years from the date of purchase. Within this period, LXNAV will, at its sole option, repair or replace any components that fail in normal use. Such repairs or replacement will be made at no charge to the customer for parts and labour, provided that the customer pays for shipping costs. This warranty does not cover failures due to abuse, misuse, accident, or unauthorized alterations or repairs.

THE WARRANTIES AND REMEDIES CONTAINED HEREIN ARE EXCLUSIVE AND IN LIEU OF ALL OTHER WARRANTIES EXPRESSED OR IMPLIED OR STATUTORY, INCLUDING ANY LIABILITY ARISING UNDER ANY WARRANTY OF MERCHANTABILITY OR FITNESS FOR A PARTICULAR PURPOSE, STATUTORY OR OTHERWISE. THIS WARRANTY GIVES YOU SPECIFIC LEGAL RIGHTS, WHICH MAY VARY FROM STATE TO STATE.

IN NO EVENT SHALL LXNAV BE LIABLE FOR ANY INCIDENTAL, SPECIAL, INDIRECT OR CONSEQUENTIAL DAMAGES, WHETHER RESULTING FROM THE USE, MISUSE, OR INABILITY TO USE THIS PRODUCT OR FROM DEFECTS IN THE PRODUCT.

Some states do not allow the exclusion of incidental or consequential damages, so the above limitations may not apply to you. LXNAV retains the exclusive right to repair or replace the unit or software, or to offer a full refund of the purchase price, at its sole discretion. SUCH REMEDY SHALL BE YOUR SOLE AND EXCLUSIVE REMEDY FOR ANY BREACH OF WARRANTY.

To obtain warranty service, contact your local LXNAV dealer or contact LXNAV directly.

2 Revision History

Date	Revision	Revised by	Description
March 2024	1	UK	Initial release
April 2024	2	UK	Updated ch.8 and 5, 5.1, 5.3, 9.2
April 2024	3	UK	Updated ch 10.1
August 2024	4	UK	Added part numbers
July 2025	4	AO	Added ch. 5.3,9.1
September 2025	6	UK	Updated ch. 9.1

3 Packing Lists

- Flap selector
- Classic M12 can cable 0.5m (optional)
- CAN connection cable for direct connection with Flap controller (optional)

4 Technical Data

4.1 Power and Consumption

Table 1: Ratings

Parameter	Symbol	Rating	Units
Power Supply	Power	28.0	V
Power Consumption	I_1	100	mA

Table 2: Electrical characteristics

Parameter	Symbol	Min	Typ	Max	Units
Power Supply	V_{in}	9.0	12.0	28.0	V
Motor current	I_h			6	A
Flap potentiometer reference voltage	V_{fr}		3		V

4.2 Size and Weight

Flap selector:

Size: 57 mm cut-out, 61x61x48mm

Weight: 300g

Flap controller:

Size:

Weight:

5 System description

5.1 Part numbers

<u>Model</u>	<u>Part number</u>	<u>Description</u>
<u>Flap selector</u>	<u>FLAP-SELECTOR</u>	<u>External Flap selector connected via CAN bus to the RPM-FLAP controller</u>
<u>Flap controller</u>	<u>FLAP-CONTROLLER</u>	<u>Controller for driving flap actuator with resistive input feedback</u>
<u>Standalone version of the Flap selector</u>	<u>FLAP-SELECTOR-ST</u>	<u>Standalone version has two push buttons at the rear side for programming flaps.</u>

5.2 Flap selector

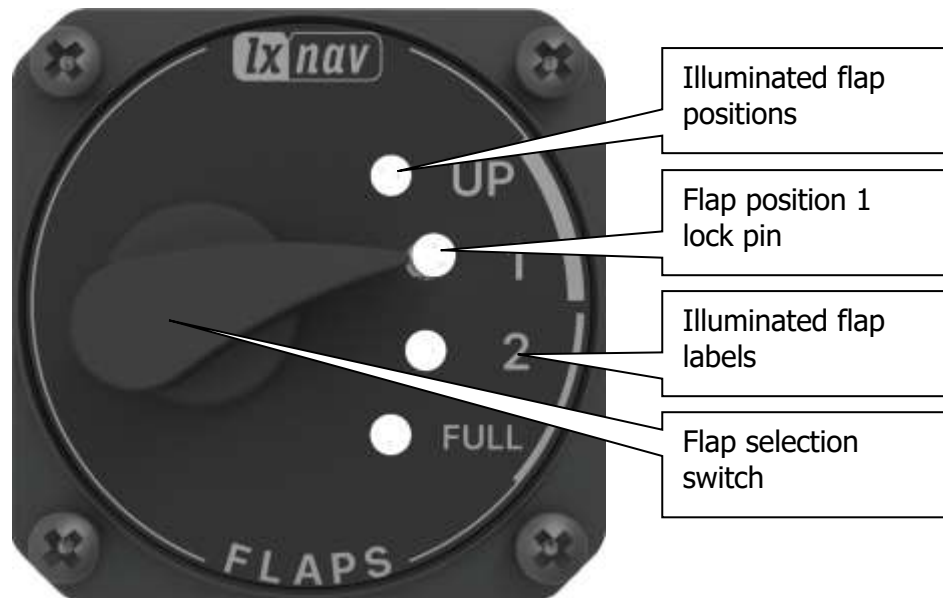

5.2.1 Flap selection switch

With flap selection switch is used to switch between flap positions. The unit has also illuminated flap positions, which are normally illuminated in white colour and flap position labels, which can be in a different colours. Colour is representing the status.

5.2.2 Buttons at the back side of the unit

Buttons at the back side of the unit are exclusively used only for programming flap positions. More about programming flap positions you can read in a chapter 6.2

5.2.3 Switching on the Unit

The unit powers up immediately, when it gets power supply.

5.2.4 Switching Off

Unit switches down, when power goes down.

5.3 Flap controller box

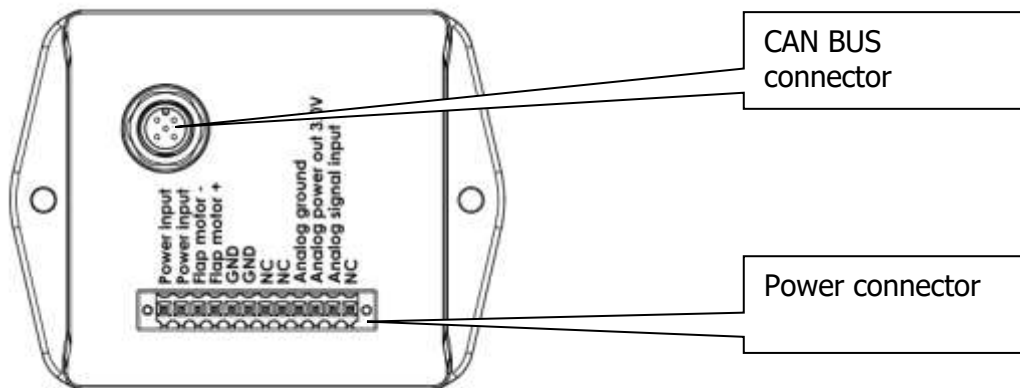

Flap controller is a single module, which controls the flap actuator (DC motor). From the flap it reads the position through external potentiometer and measures angle of the flap. Flap positions/presets are stored in this unit. They can be programmed with flap selector or RPM flap controller display.

6 Operating Modes

Flap selector can operate in two modes, normal or setup mode.

6.1 Normal mode

In normal mode, user can select the flap position and read the status of the flap. When the pilot change the flap position the flap selector sends a command to a flap controller for the new flap position. Until flap is moving to required position a green number of the flap will blink. When flap reaches the required position the green label of the flap position will stop blinking and will become solid green. In case of flap motor failure or position is not reached a label will bling red.

Flap is on position



Flap is moving to the position 1



Flap didn't reach the required position 1



In any case red indications indicates an error state of the flap system.

6.1.1 Error states

No communication with the flap controller



No data form the flap controller



Flap didn't reach the required position



6.2 Setup mode (Standalone version)

Setup mode is intended to use only for programming the flap positions.



Use the setup mode only when aircraft is on the ground and not flying.



Standalone version works only if flap controller box is connected to the flap selector via CAN BUS cable



Flap selector can be entered into the setup mode if you push and hold both push buttons before power on the unit. Then keep holding both buttons until flap labels start blinking blue. Release the push buttons, select the required flap position. With pushing buttons up and down, you can drive flap to the required flap position. You can repeat the setting up flap position for other positions.

When finished, just turn off the unit and turn it back on. The unit will start in normal operation mode.

Please check if all flap position are valid and if the driving flap operates properly.

7 Firmware Update

Firmware update can be performed only by external device which has CAN bus connection and SD card (Classic RPM flap controller). Please enter the password and 89891 and select the firmware file App_FSAC_x.xx.lxfw. Please visit our webpage www.lxnav.com and download the firmware update.

You can also subscribe to a newsletter to automatically receive news about the system.

8 Backup - manual/automatic - switch flip over (optional)

Along Flap Selector controller unit can be used panel mounted switches with whom user can select between manual or automatic control of flaps pitch. The unit has two switches. With left toggle switch user can choose between manual or automatic control of function for the switch is used. When lever is switched up, automatic function is enabled (motors are driven by Flap Selectors unit) and when the lever is down, manual control is enabled. In this option user can override flap position with right momentary toggle switch. When pushing lever up, flaps go up (negative movement), when pushing switch down, flaps go down (positive movement). In following chapters, 9.3, is described, how switch unit must be wired together with electric motor and Flap Selector controller.



Figure 1: Panel mounted switch unit

9 Wirings

9.1 FLAP controller standalone version

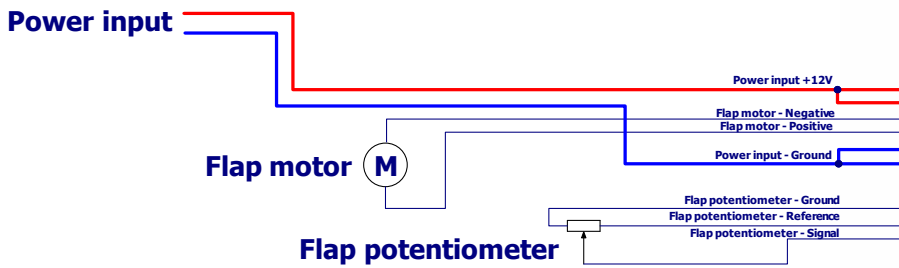
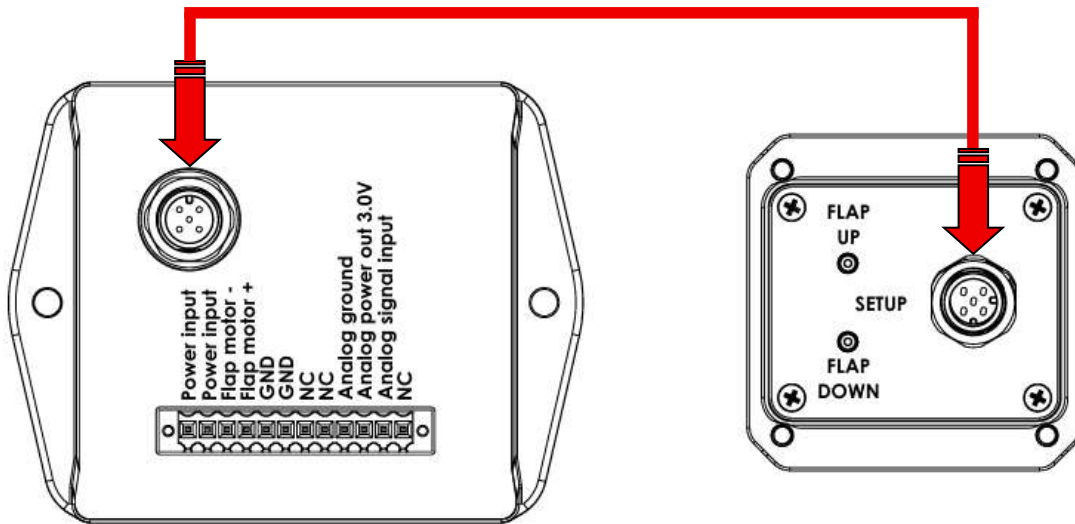

9.2 Flap/RPM controller pinout and wiring diagram

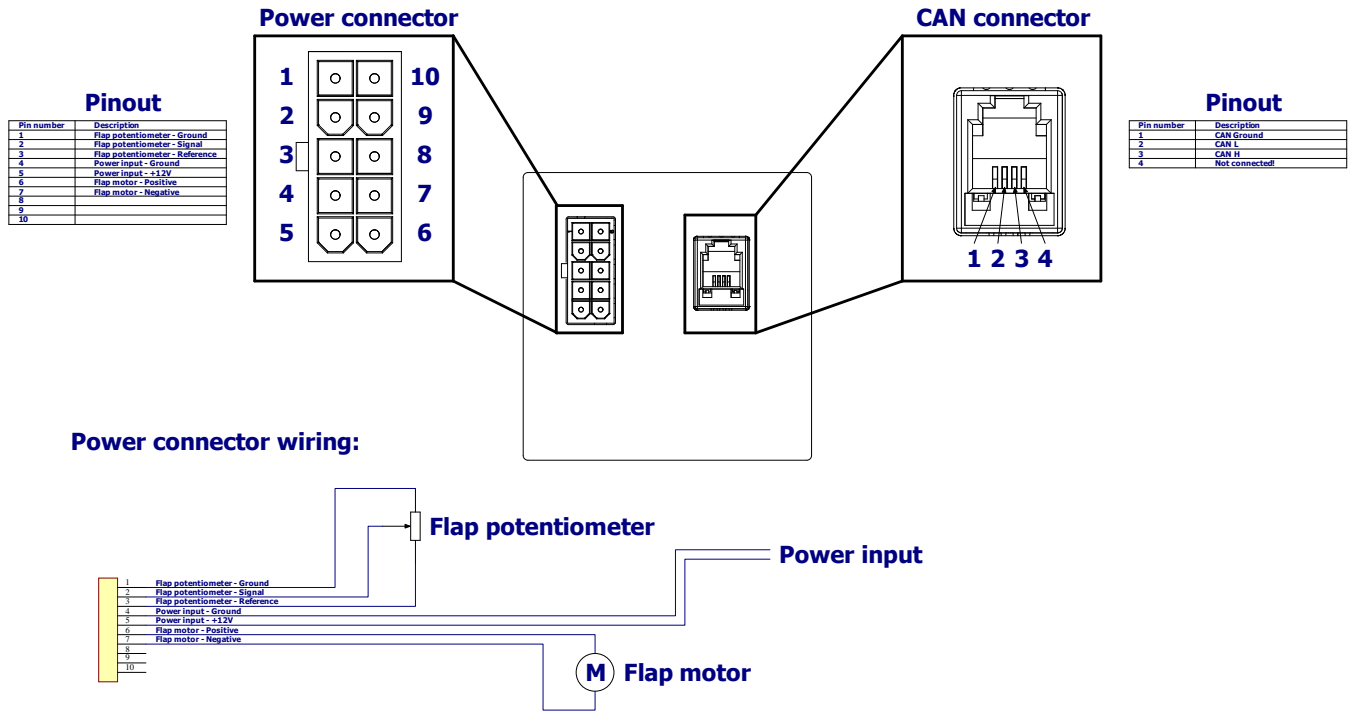

9.3 Flap motor control backup switch

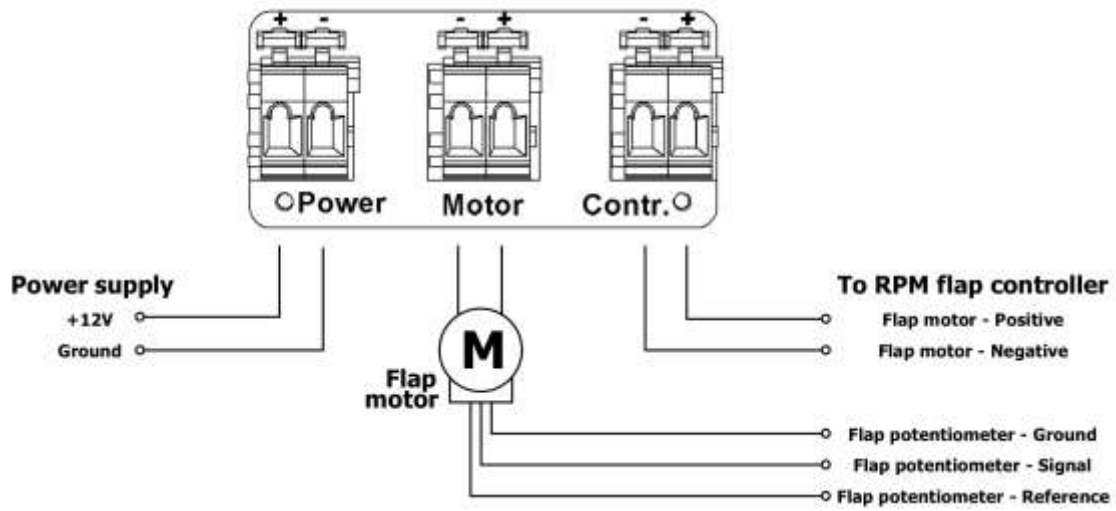
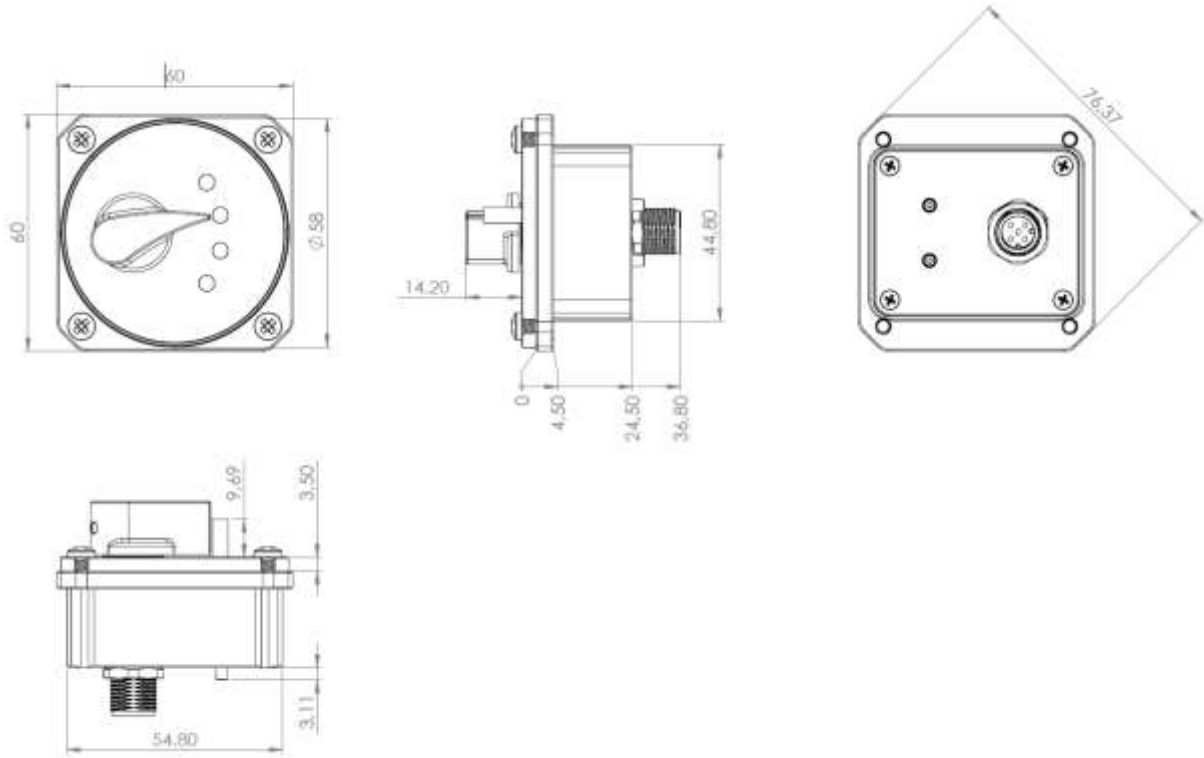

Figure 2: Backup switch connections for flap motor controller

10 Dimensions

10.1 Flap Selector



10.2 Backup switch

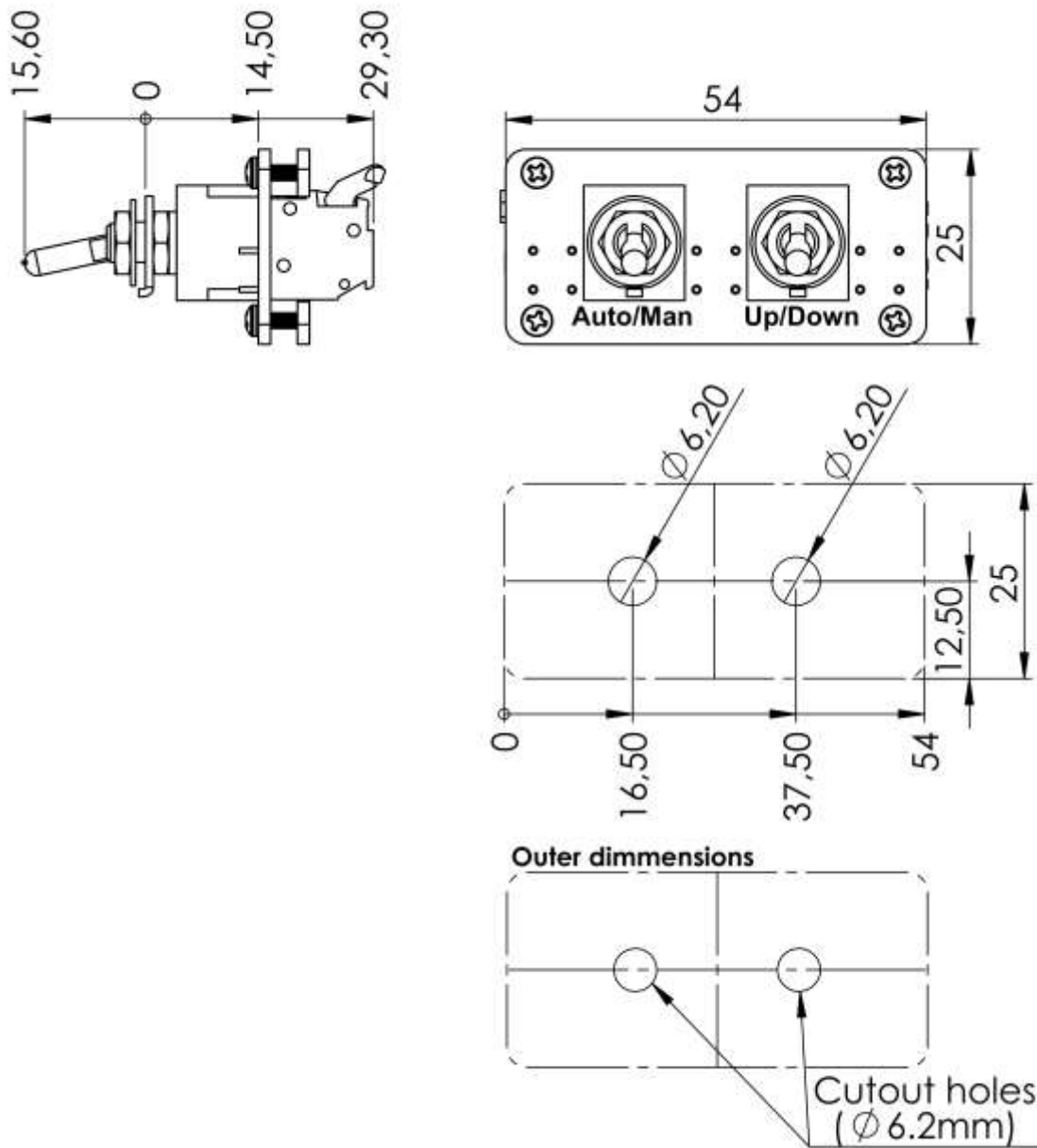

Figure 3: Dimensions and panel cutout holes (not to scale)

10.3 Standalone box

