

LXNAV CAN Bridge

Installation manual rev 4





[LXNAV d.o.o. • Kidričeva 24a, 3000 Celje, Slovenia • tel +386 592 33 400 fax +386 599 33 522](mailto:info@lxnav.com)
[info@lxnav.com • www.lxnav.com](mailto:info@lxnav.com)

1	Important Notices	3
1.1	Limited Warranty	4
2	Installations	5
2.1	Packing List	5
2.2	Basics	5
2.3	Installation	6
2.4	Wirings	6
2.4.1	Radios	6
2.4.1.1	Funkwerk ATR833	6
2.4.1.2	Dittel KRT2	7
2.4.1.3	Trig TY 91/92 (no TC90 head)	8
2.4.1.4	Trig TY 91/92 (with TC90 head)	8
2.4.1.5	Becker AR6201 / RT6201	9
2.4.2	Transponders	11
2.4.2.1	Becker BXP6402	11
2.4.2.2	Trig TT 21/22	11
3	Revision History	12

1 Important Notices

Information in this document is subject to change without notice. LXNAV reserves the right to change or improve their products and to make changes in the content of this material without obligation to notify any person or organisation of such changes or improvements.



A Yellow triangle is shown for parts of the manual which should be read very carefully and are important for operating the system.



Notes with a red triangle describe procedures which are critical and may result in loss of data or any other critical situation.



A bulb icon is shown when a useful hint is provided to the reader.

1.1 Limited Warranty

This LXNAV product is warranted to be free from defects in materials or workmanship for two years from the date of purchase. Within this period, LXNAV will, at its sole discretion, repair or replace any components that fail in normal use. Such repairs or replacement will be made at no charge to the customer for parts and labour, provided that the customer shall be responsible for any transportation cost. This warranty does not cover failures due to abuse, misuse, accident, or unauthorised alterations or repairs.

THE WARRANTIES AND REMEDIES CONTAINED HEREIN ARE EXCLUSIVE AND IN LIEU OF ALL OTHER WARRANTIES EXPRESSED OR IMPLIED OR STATUTORY, INCLUDING ANY LIABILITY ARISING UNDER ANY WARRANTY OF MERCHANTABILITY OR FITNESS FOR A PARTICULAR PURPOSE, STATUTORY OR OTHERWISE. THIS WARRANTY GIVES YOU SPECIFIC LEGAL RIGHTS, WHICH MAY VARY FROM STATE TO STATE.

IN NO EVENT SHALL LXNAV BE LIABLE FOR ANY INCIDENTAL, SPECIAL, INDIRECT OR CONSEQUENTIAL DAMAGES, WHETHER RESULTING FROM THE USE, MISUSE, OR INABILITY TO USE THIS PRODUCT OR FROM DEFECTS IN THE PRODUCT. Some states do not allow the exclusion of incidental or consequential damages, so the above limitations may not apply to you. LXNAV retains the exclusive right to repair or replace the unit or software, or to offer a full refund of the purchase price, at its sole discretion. SUCH REMEDY SHALL BE YOUR SOLE AND EXCLUSIVE REMEDY FOR ANY BREACH OF WARRANTY.

To obtain warranty service, contact your local LXNAV dealer or contact LXNAV directly.

August 2017

© 2017 LXNAV. All rights reserved.

2 Installations

2.1 Packing List

- CAN Bridge
- 2 x M12 to DB9(CAN BUS cable) – only with for Sxxxx vario

2.2 Basics



LXNAV CAN bridge is connected to the CAN bus through a male or female M12 connector. Power is derived from CAN bus and no external power is needed. The device does not contain a CAN terminator.

On the other side it has a 10 pin 3.5mm header. With following interfaces:

- RS232
- RS485
- RS422



Only one device (radio/transponder) can be connected to to one bridge.

Additionally, it has two open-drain outputs for controlling various devices that are connected to it.

2.3 Installation

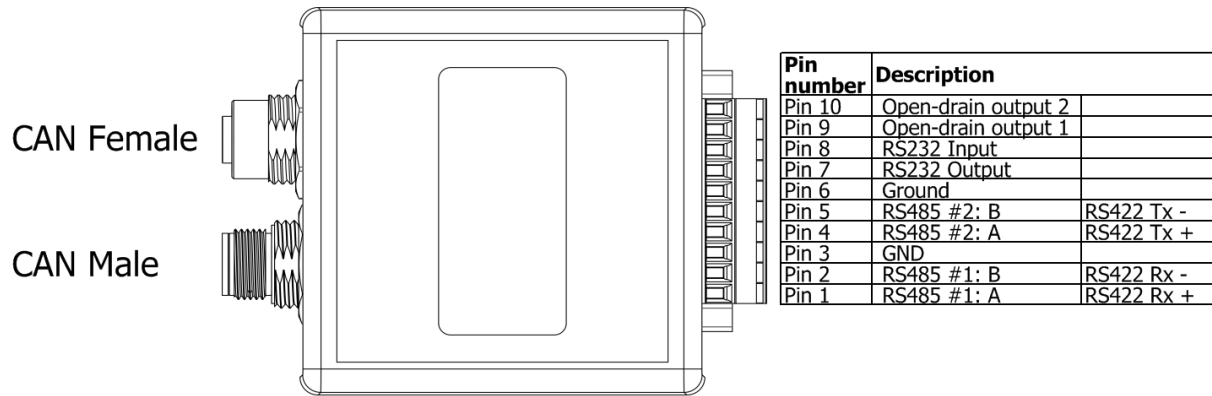

If CAN bridge is connected to S-vario, additionally is delivered M12 to DB9 (CAN BUS cable)

2.4 Wirings

The wiring diagrams show the minimum required connection for communication between a LXNAV instrument and a radio or transponder. The user should check the manual of the connected device for any further information.

2.4.1 Radios

2.4.1.1 Funkwerk ATR833

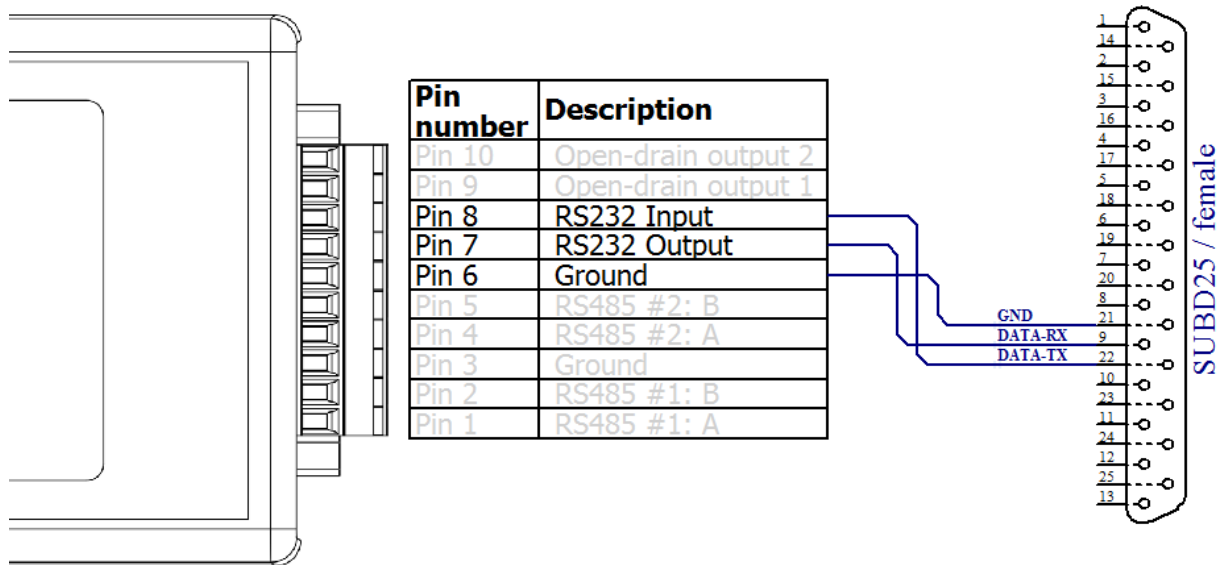

2.4.1.2 Dittel KRT2

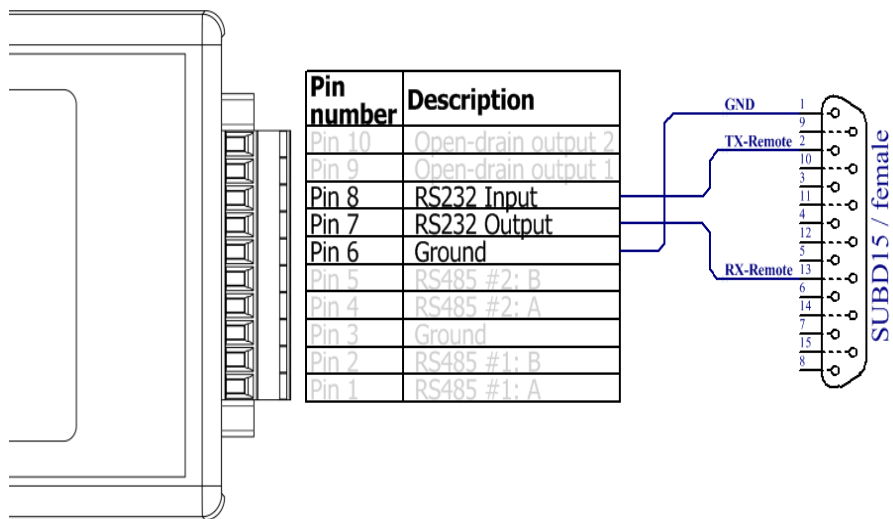

2.4.1.3 Trig TY 91/92 (no TC90 head)

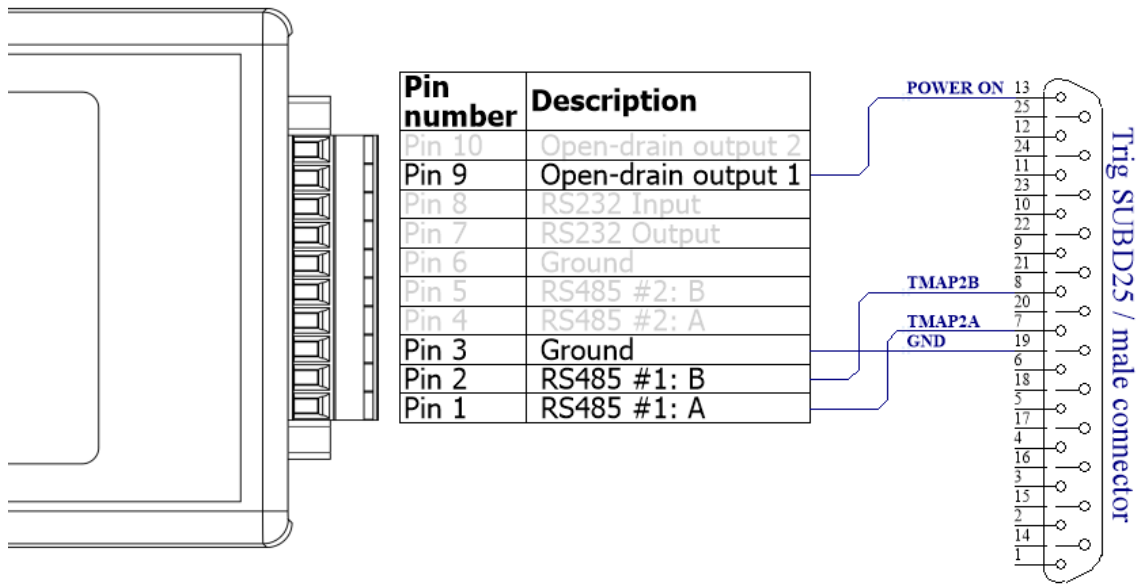

2.4.1.4 Trig TY 91/92 (with TC90 head)

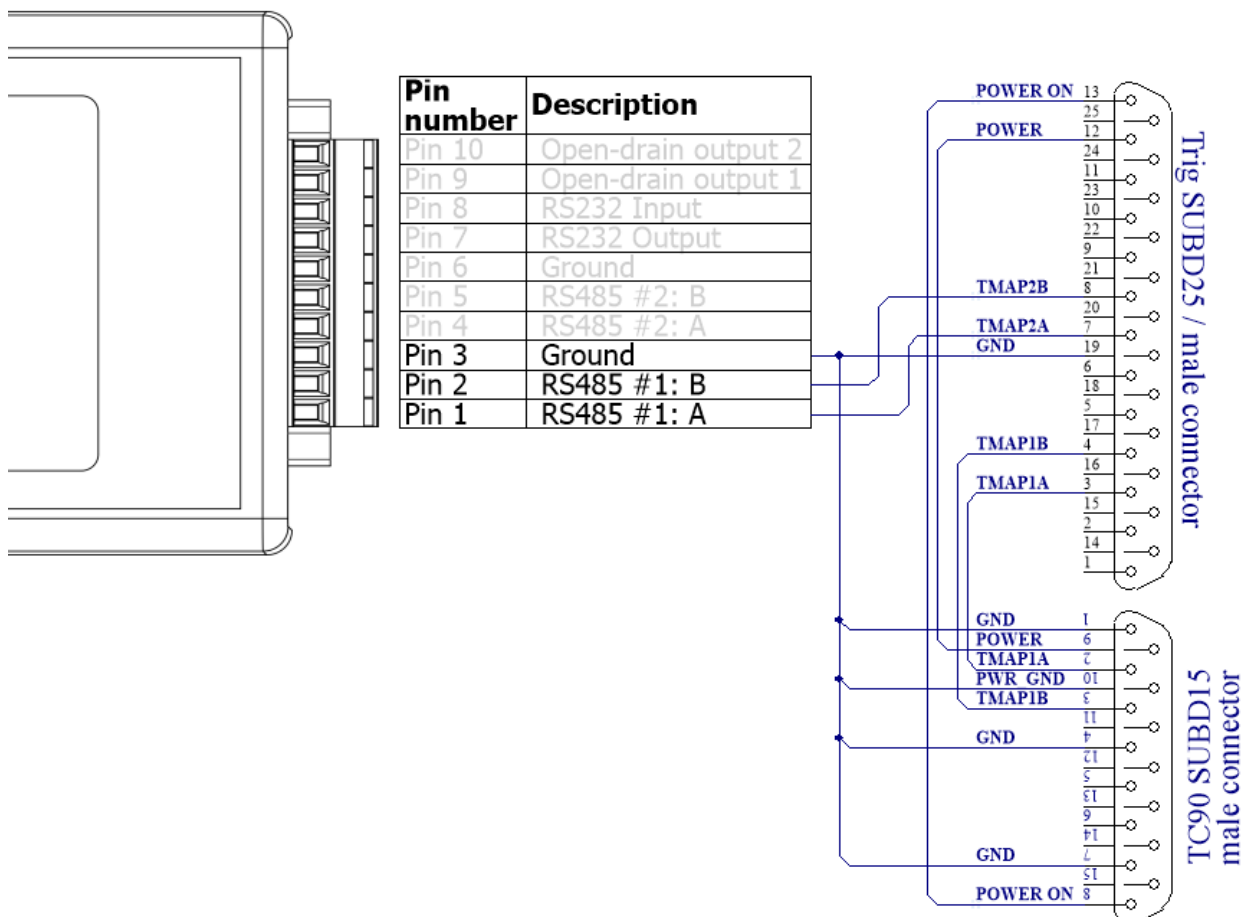

2.4.1.5 Becker AR6201 / RT6201

I. AR6201 single seater

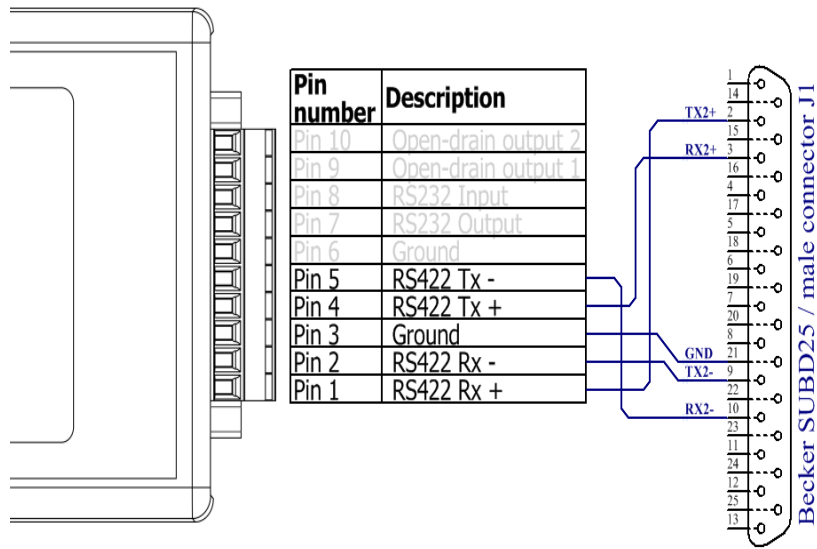

II. AR6201 twin seater

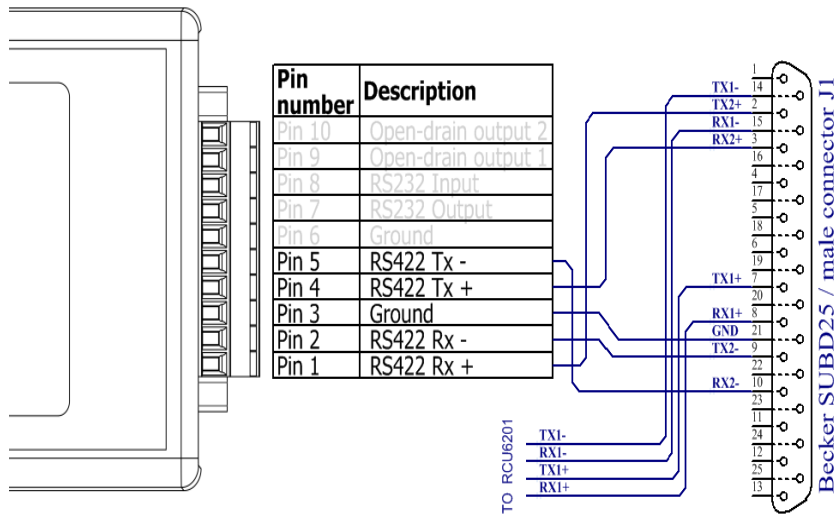

III. RT6201 single seater remote control

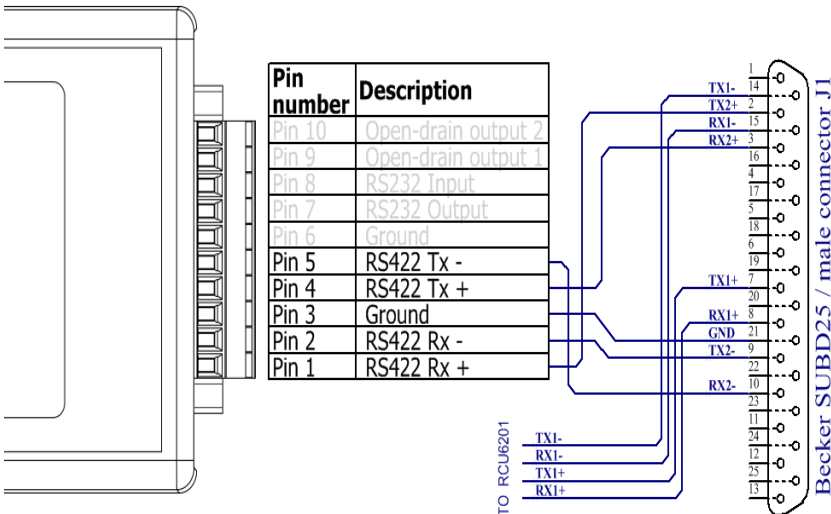

2.4.2 Transponders

2.4.2.1 Becker BXP6402

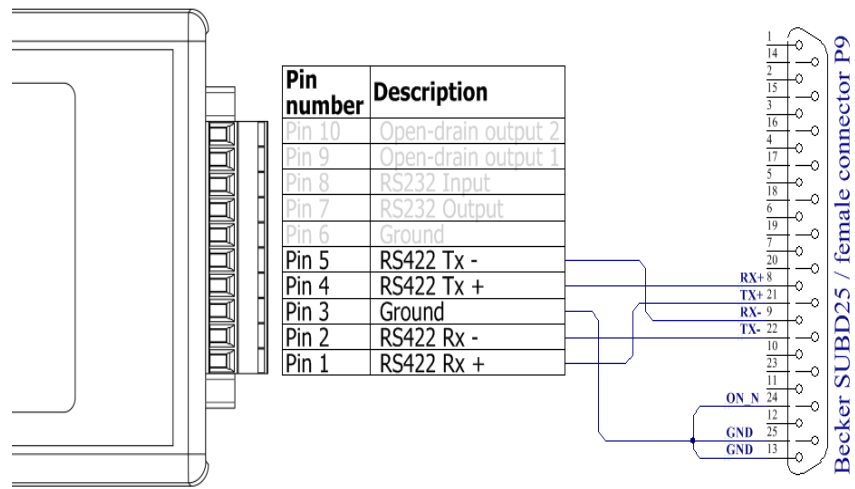

2.4.2.2 Trig TT 21/22

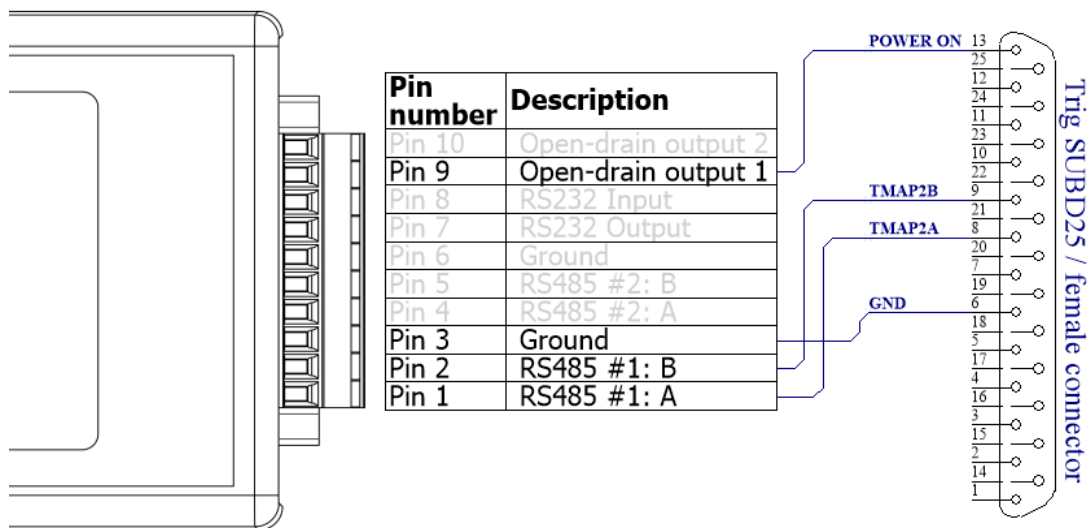

3 Revision History

July 2016	Rev 1	Initial release of owner manual
August 2017	Rev 2	Modified wiring pinout on CanBridge for Trig units: 2.4.1.3, 2.4.1.4, 2.4.2.2
August 2018	Rev 3	Modified wiring for ATR833: 2.4.1.1
February 2024	Rev 4	Updated chapter Error! Reference source not found. ,2.1